

Cylindrical Blender/Dryers Specifications and Dimensions

STANDARD FEATURES:

.33 through 343 cubic feet capacity

Stainless steel wetted parts

Ribbon agitator for center discharge

Designed for vacuum operation

Baffled jacket for heating or cooling

80 grit finish on interior and exterior stainless steel surfaces

Manway and inlet connections

Safety limit switch on manway

Stuffing boxes with easily disassembled split housing

Teflon braided packing

Manually operated slide gate valve

All exterior non-stainless surfaces are painted with a white two-part epoxy coating

Single speed drive

230/460 volt, 60 Hz, three phase, TEFC motors
(see options for starters and controls)

Blender is mounted on supports providing a discharge clearance of 36"

Blender suitable for 30 lbs. per cu. ft.

OPTIONAL FEATURES:

Wetted parts of carbon steel, stainless steel type 316 and special alloys

Continuous ribbon agitator for end discharge, interrupted ribbon for higher density materials, paddles for full or partial loads

Vacuum or pressure construction

Sanitary type construction

Spherical, Flush Type Ball, paddle, and knife gate discharge valves

Horsepower to suit higher density materials

Explosion-proof or washdown motors and controls

Controls such as inverters, motor starters, and operator stations are available

Electronic or mechanical soft start control systems

Spray nozzles for liquid introduction

Lumpbreakers for solids or agglomerates size reduction

Dimpled or baffled jackets for heating or cooling

Thermocouples for temperature readout

Special gasket materials such as Viton are available

Lantern rings for stuffing boxes



CHARLES ROSS & SON COMPANY

P.O. Box 12308, 710 Old Willets Path, Hauppauge, NY 11788 Fax: 1-631-234-0691 Tel: 1-631-234-0500
Website: www.mixers.com Email: sales@mixers.com

Cylindrical Blender/Dryers Specifications and Dimensions

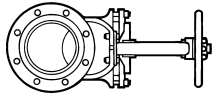

Slide Gate Valve - ideal for dust tight, liquid tight, or vacuum applications

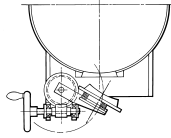

Flush Plug Valve - equipped for manual or pneumatic operation, this valve eliminates dead spots in the blender trough

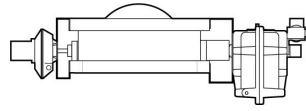

Spherical Valve - pneumatically operated, this valve minimizes dead space and provides a large discharge opening

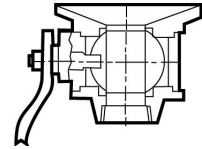

Flush Ball Valve - for vacuum/pressure or liquid/solid applications

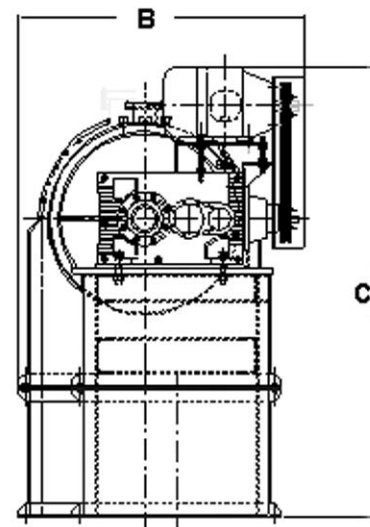
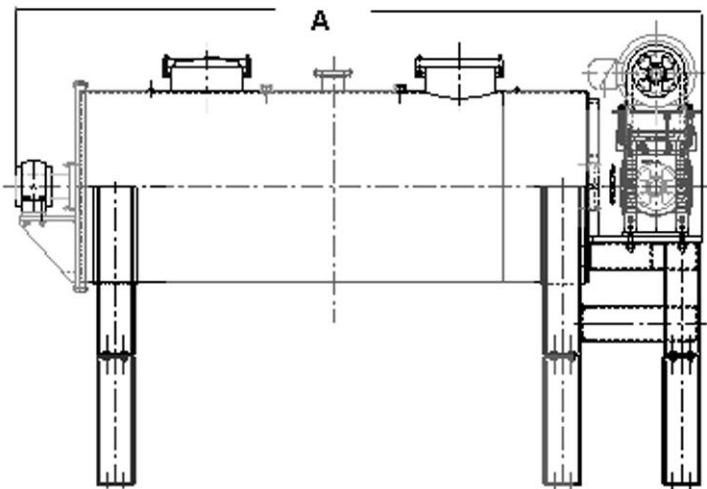

MODEL NUMBER	WORKING CAPACITY		FULL CAPACITY		MOTOR H.P.	AGITATOR RPM	TROUGH SIZE		OVERALL DIMENSION			SHIPPING WT. LBS.
	CU.FT.	GAL.	CU.FT.	GAL.			DIAMETER	LENGTH	A	B	C	
42C-1/2	0.33	2	1/2	3.7	3/4	66	9	16	42	25	35	300
42C-1	0.66	5	1	7 1/2	3/4	54	12	20	45	28	45	350
42C-5	3.5	25	5	37	3	46	17	42	67	30	34	800
42C-10	6	45	7	70	7 1/2	39	21	48	77	33	38	1200
42C-18	11	86	17	125	10	32	25	60	93	39	41	1500
42C-25	16	120	24	180	15	26	30	60	91	39	47	2300
42C-36	24	179	36	270	20	26	36	78	115	47	47	2800
42C-52	32	258	49	389	25	24	36	84	125	52	54	3900
42C-62.5	41.5	310	62	468	25	21	38	96	142	47	81	4600
42C-71	46	352	69	531	25	21	40	96	144	51	83	5200
42C-80	52	398	78	598	30	21	40	108	152	51	83	6000
42C-100	64	498	95	748	PER APPLICATION	20	42	120	166	56	86	6600
42C-120	80	597	120	868	PER APPLICATION	19	45	136	166	60	90	8000
42C-155	105	772	155	1159	PER APPLICATION	16	54	120	166	65	102	3900
42C-180	120	895	180	1346	PER APPLICATION	15	58	120	166	67	106	10200
42C-215	143	1072	266	1608	PER APPLICATION	15	58	144	190	70	106	12500
42C-270	177	1343	320	2020	PER APPLICATION	13	64	144	203	75	114	12750
42C-325	213	1616	365	2431	PER APPLICATION	12	70	156	203	77	120	14025
42C-385	250	1915	505	2880	PER APPLICATION	11	72	156	203	85	120	15300
42C-515	337	2562	515	3852	PER APPLICATION	11	72	220	254	86	126	20500